

VARIMETER Phase Sequence Relay MK 9056N



Your Advantage

- Correct sense of rotation of motors
- Simple wiring

Features

- According to IEC/EN 60 255-1
- Detection of wrong phase sequence
- LED indication of rotation
- 2 changeover contacts
- Wire connection: also 2 x 1.5 mm² stranded ferruled, or 2 x 2.5 mm² solid DIN 46 228-1/-2/-3/-4
- As option with pluggable terminal blocks for easy exchange of devices
 - with screw terminals
 - or with cage clamp terminals
- Width 22.5 mm

Product Description

The MK 9056N detect wrong phase sequence in 3-phase systems. To monitor phase failure it is more suitable to use an Asymmetry relay e.g. MK 9040N.

Approvals and Markings



Function Diagram

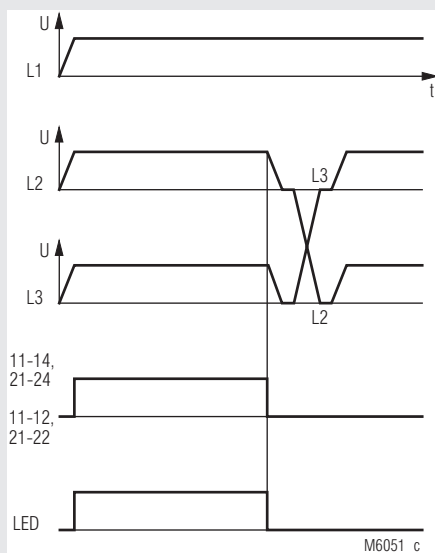

Circuit Diagram

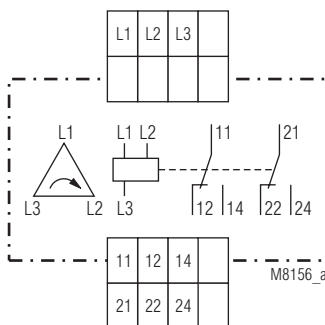

Connection Terminals

Terminal designation	Signal designation
L1, L2, L3	Connection of the monitoring 3-phase system
11, 12, 14, 21, 22, 24	"incorrect phase sequence-signaling relays (2 changeover contacts)"

Indicators

green LED: on, when corresponding output relay is active

Technical Data

Input

Nominal voltage U_N : 3 AC 42 ... 60 V, 100 ... 127 V
3 AC 220 ... 240, 380 ... 500 V
Voltage range: 0.9 ... 1.1 U_N
Nominal frequency of U_N : 50 / 60 Hz
Nominal consumption: approx. 2 W

Output

Contact: 2 changeover contacts
Operate / release delay: < 100 / 50 ms
Thermal current I_{th} : 5 A
Switching capacity
to AC 15
NO contact: 3 A / AC 230 V IEC/EN 60 947-5-1
NC contact: 1 A / AC 230 V IEC/EN 60 947-5-1
to DC 13
NO contact: 1 A / DC 24 V IEC/EN 60 947-5-1
NC contact: 1 A / DC 24 V IEC/EN 60 947-5-1
Electrical life
to AC 15 at 3 A, AC 230 V: 5 x 10⁵ switch. cycles IEC/EN 60 947-5-1
Short circuit strength
max. fuse rating: 4 A gL IEC/EN 60 947-5-1
Mechanical life: > 20 x 10⁶ switching cycles

General Data

Operating mode: Continuous operation
Temperature range:
Operation: - 20 ... + 60°C
Storage: - 20 ... + 60°C
Altitude: < 2.000 m
Clearance and creepage distances
rated impulse voltage /
pollution degree: 4 kV / 2 IEC 60 664-1

Technical Data

EMC		
Electrostatic discharge:	8 kV (air)	IEC/EN 61 000-4-2
HF irradiation		
80 MHz ... 2.7 GHz:	10 V / m	IEC/EN 61 000-4-3
Fast transients:	2 kV	IEC/EN 61 000-4-4
Surge voltages between wires for power supply:	2 kV	IEC/EN 61 000-4-5
between wire and ground:	4 kV	IEC/EN 61 000-4-5
HF wire guided:	10 V	IEC/EN 61 000-4-6
Interference suppression:	Limit value class B	EN 55 011
Degree of protection		
Housing:	IP 40	IEC/EN 60 529
Terminals:	IP 20	IEC/EN 60 529
Housing:		
	Thermoplastic with V0 behaviour according to UL subject 94	
Vibration resistance:		
	Amplitude 0.35 mm, frequency 10 ... 55 Hz, IEC/EN 60 068-2-6 20 / 060 / 04 IEC/EN 60 068-1 EN 50 005	
Climate resistance:		
Terminal designation:		
Wire connection		
Screw terminals (integrated):		
	1 x 4 mm ² solid or 1 x 2.5 mm ² stranded ferruled or 2 x 1.5 mm ² stranded ferruled or 2 x 2.5 mm ² solid	

Insulation of wires or sleeve length:	8 mm
Plug in with screw terminals	
max. cross section for connection:	1 x 2.5 mm ² solid or 1 x 2.5 mm ² stranded ferruled

Insulation of wires or sleeve length:	8 mm
Plug in with cage clamp terminals	
max. cross section for connection:	1 x 4 mm ² solid or 1 x 2.5 mm ² stranded ferruled

min. cross section for connection:	0.5 mm ²
Insulation of wires or sleeve length:	12 ^{+0.5} mm
Wire fixing:	
	Plus-minus terminal screws M 3.5 box terminals with wire protection or cage clamp terminals
Fixing torque:	0.8 Nm
Mounting:	DIN rail IEC/EN 60 715
Weight:	approx. 140 g

Dimensions

Width x height x depth:	
MK 9056N:	22.5 x 90 x 97 mm
MK 9056N PC:	22.5 x 111 x 97 mm
MK 9056N PS:	22.5 x 104 x 97 mm

CCC-Data

Auxiliary voltage U_N:	3 AC 42-60 V, 3 AC 100-127V, 3 AC 220-240 V
---	--

Switching capacity	
to AC 15	
NO contact:	1,5 A / AC 230 V IEC/EN 60 947-5-1



Technical data that is not stated in the CCC-Data, can be found in the technical data section.

Standard Types

MK 9056N.12 AC 380 ... 500 V 50 / 60 Hz	
Article number:	0054183
• Output:	2 changeover contacts
• Nominal voltage U _N :	AC 380 ... 500 V
• Width:	22.5 mm

Ordering Example

MK 9056N. 12 _ _ / 3 AC 380 ... 500 V 50 / 60 Hz

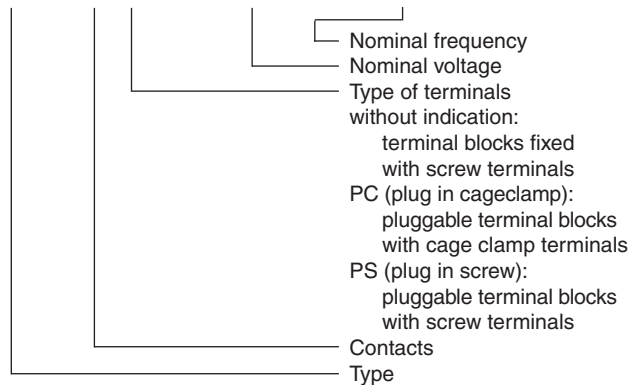

Options with Pluggable Terminal Blocks

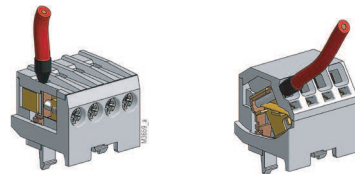

Screw terminal (PS/plugin screw) Cage clamp (PC/plugin cage clamp)

Notes

Removing the terminal blocks with cage clamp terminals

1. The unit has to be disconnected.
2. Insert a screwdriver in the side recess of the front plate.
3. Turn the screwdriver to the right and left.
4. Please note that the terminal blocks have to be mounted on the belonging plug in terminations.

